



Meat Press

MP10

3D Pressing



Meat Press Summary:

- 3D pressing - shapes and forms meat to customers specification
- 10 cycles per minute
- Designed for efficient productivity
 - Fast die change (no tools required)
 - Stainless steel construction and innovative design provides rapid strip down for cleaning
- No air or water required
- Built for high throughput processing environments
- Low carbon footprint
- Range of auto loading options available



Meat Press Technical Specification:

- 7.5KW hydraulic power pack
- Low energy immersion heater – optimum oil viscosity maintained
- 3D pressing
- HMI touch screen
- Multiple product programs
- Stainless steel construction
- CE marked
- 4 Safety guard switches
- Cleaning – operating area designed for normal factory practice



Dimensions:

- Weight: 2200KG
- Length: 3.7m
- Width: 1.2m
- Height: 1.8m

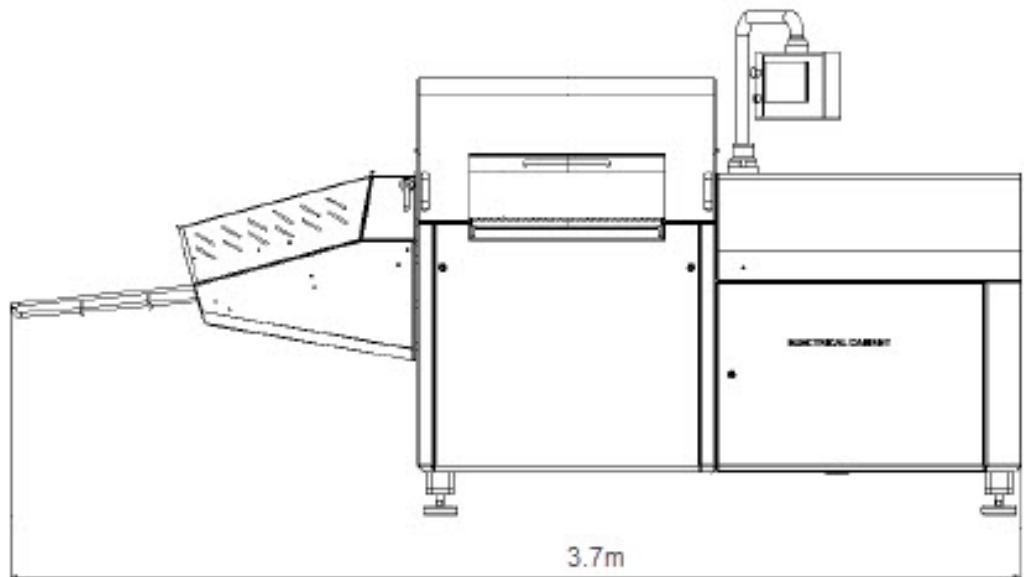
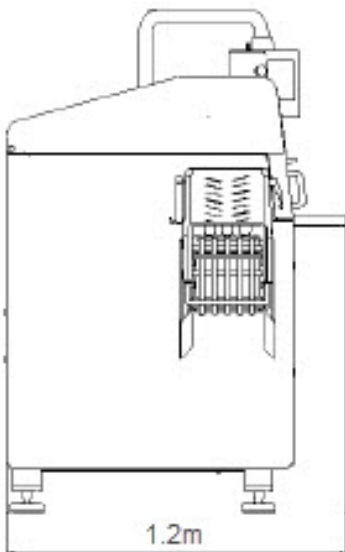

Wrightfield Ltd
Progress Way, Mid Suffolk Business Park
Eye, Suffolk, IP23 7HU, UK

**MADE IN
BRITAIN** 

www.wrightfield.co.uk - Sales@wrightfield.co.uk - +44 (0) 1379 872800